

# Illustrated Parts Catalog

---

## SA800/801



# SA800/801

# Illustrated Parts Catalog



1

2

3

4

5

6

7

# TABLE OF CONTENTS

Description . . . . .	1
Basic Assembly (Figure 1) . . . . .	2
Stepper/Carriage (Figure 2) . . . . .	6
Cartridge Guide . . . . .	8
Front Plate (Figure 4) . . . . .	10
Numerical Index . . . . .	12





## **DESCRIPTION**

### **General**

The Illustrated Parts Catalog is arranged so that the figures will always precede the parts listings and when possible be on the opposite page.

The first number in the list will always refer to the figure and the second number to the reference number of the part within the figure.

When an assembly is referred to within a figure and a further breakdown is shown on another figure then the reference figure will be called out.

### **Indented Level**

The parts list is indented to show the levels of assembly within a figure. The major assembly will always be level 1, all parts or assemblies that attach to that assembly will be level 2 and assemblies within level 2 will have their attaching parts level 3 and so on.

### **Quantity Per Assembly**

The quantity listed is the quantity used on the major assembly. Major Assemblies will never have a quantity listed.

### **Numerical Index**

The numerical index lists all parts in part number sequence and is cross referenced to the figure and reference number.

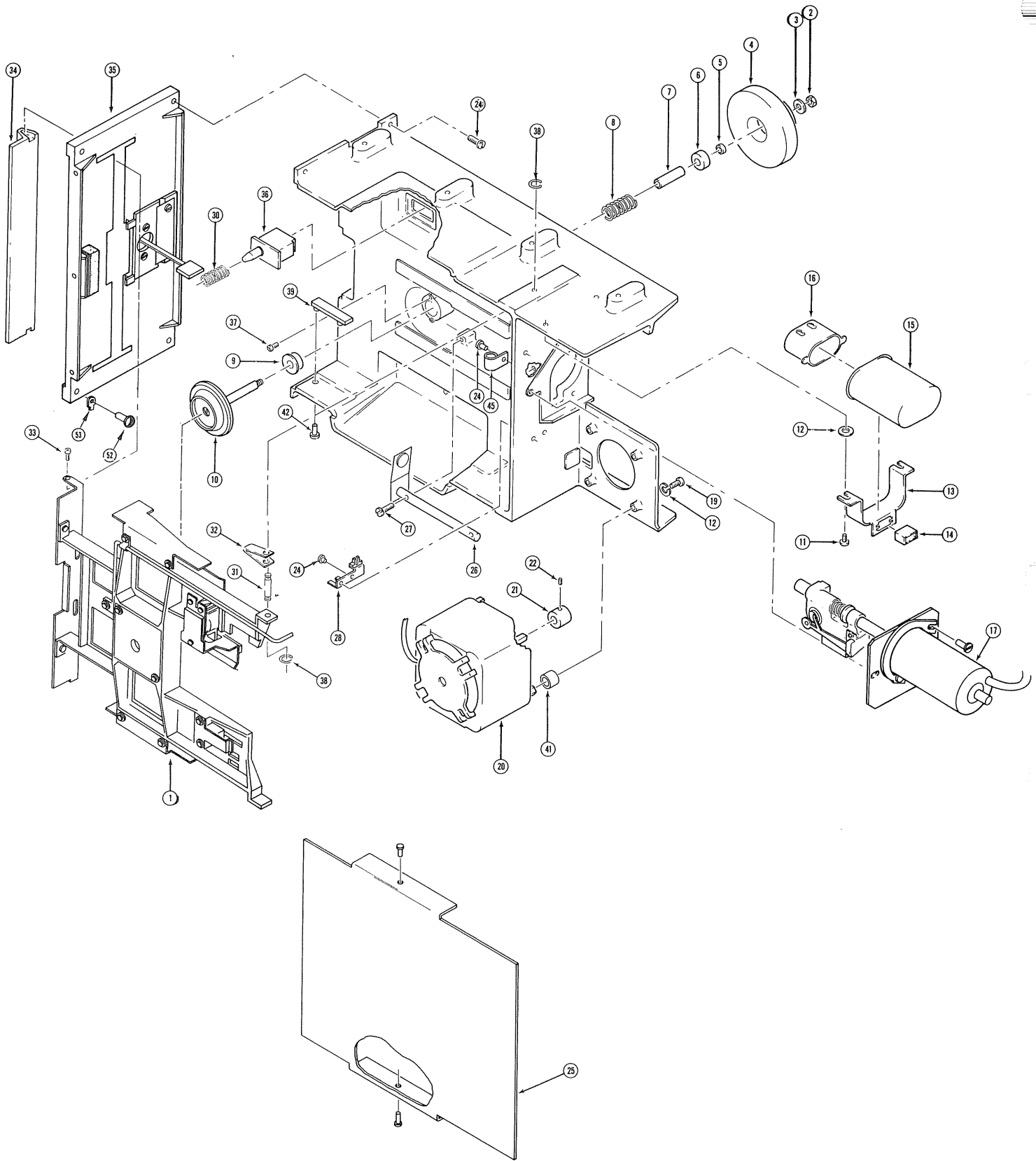

Figure 1 (1 of 2)

FIGURE & REF. NUMBER	PART NUMBER	DESCRIPTION				QTY PER ASM.
		1	2	3	4	
1		DRIVE ASSEMBLY SA800/801				
-1	50550	. CARTRIDGE GUIDE ASSEMBLY (SEE FIG. 3)				1
-2	10025	. NUT, 8-32				1
-3	12509	. WASHER, SPRING				2
-4	50016	. PULLEY ASSEMBLY, SPINDLE				1
-5	50019	. SPACER, SPINDLE-SHORT				1
-6	10800	. BEARING, SPINDLE				1
-7	50018	. SPACER, SPINDLE---LONG				1
-8	50166	. SPRING, SPINDLE				1
-9	10801	. FLANGED BEARING, SPINDLE				1
-10	50561	. HUB ASSEMBLY, SPINDLE				1
-11	12015	. SCREW, 8-32x.312				5
-12	12500	. WASHER; LOCK # 8				2
-13	50098	. BRACKET				1
-14	10150	. HOUSING, 3 PIN CONNECTOR				1
-15	10095	. CAPACITOR, 110 V 50/60 HZ (BODINE MTR ONLY)				1
	15004	. CAPACITOR, 220 V 50/60 HZ OR 110V ORIENTAL MTR				
-16	10148	. RUBBER BOOT				1
-17		. STEPPER/CARRIAGE ASSEMBLY (SEE FIG. 2)				1
-19	12028	. SCREW, 8-32x.750				4
-20	50443	. MOTOR, 110 VOLT 50/60 HZ KIT				1
	50301	. MOTOR, 208/230/220 VOLT 50/60 HZ				
-21	50358	. PULLEY, 60 HZ				1
	50357	. PULLEY, 50 HZ				
-22	11904	. SCREW, SET 6-32x.125				1
-23	10378	. CABLE CLAMP, 1/8 INCH				1
-24	12013	. SCREW 6-32x.312 (12014 FOR ZINC FACEPLATE)				11
	10191	. SCREW 6-32x.438 -800R				2
-25	50440	. DUST COVER KIT (OPTIONAL)				1
	12023	. . SCREW, THD. FORM, PAN HD.				2
	50009	. . COVER				1
-26	50522	. SPRING/GUIDE ASM				1
-27	12012	. SCREW, 4-40x.375				2
-28	50121	. DETECTOR ASSEMBLY, TRACK 0				1
-30	50582	. SPRING ASSEMBLY, DOOR OPEN (STANDARD)				1
	50583	. SPRING ASSEMBLY, DOOR OPEN (HORZ. MNT, PCB DOWN)				
-31	50167	. PIVOT TOP				1
	50670	. PIVOT TOP (STANDARD) (800R)				
-32	50168	. SPRING, BIAS				1
-33	11905	. SCREW, B.V.				2
-34	50142	. HANDLE				1
-35		. FRONT PLATE ASSEMBLY (SEE FIG. 4)				1
-36	17200	. SWITCH, DOOR OPEN				1
-37	12011	. SCREW, 4-40x.250				2
-38	11305	. CLIP				2
-39	50559	. DEFLECTOR				2
-41	50602	. SPACER				4
-42	12032	. SCREW, # 8x.50 LG TAPPING				2



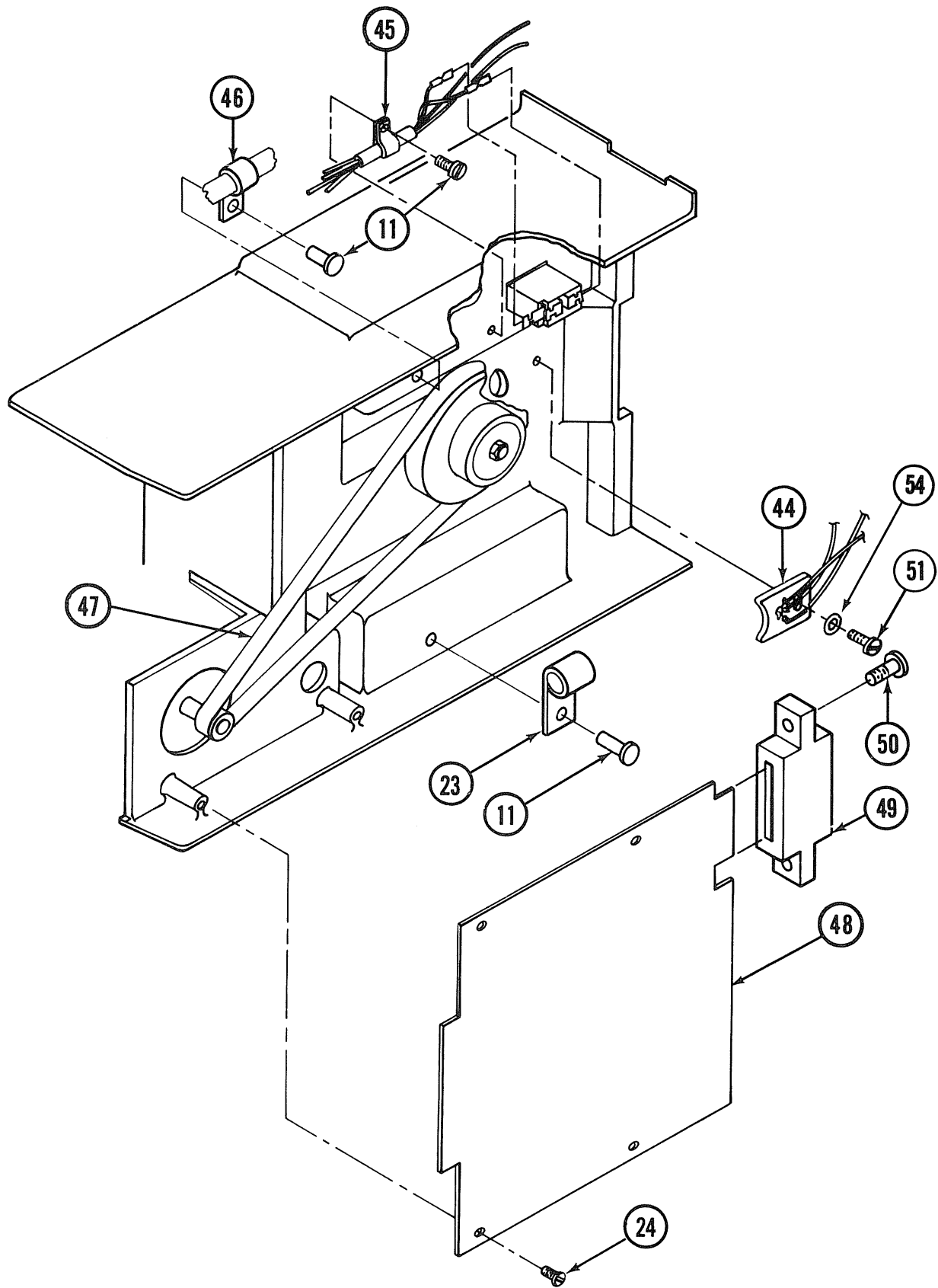

Figure 1 (2 of 2)



FIGURE & REF. NUMBER	PART NUMBER	DESCRIPTION				QTY PER ASM.
		1	2	3	4	
-44	50128	.	PHOTRANSISTOR AND CABLE ASSEMBLY			1
-45	10375	.	CABLE CLAMP, 3/16"			2
-46	10264	.	CABLE CLAMP, 3/8"			1
-47	50356	.	BELT (60 HZ)			1
	50355	.	BELT (50 HZ)			1
-48	25102	.	PCB (SA 800, -5V, NO DATA SEP)			1
	25103	.	PCB (SA 800, -12/-15V, NO DATA SEP)			
	25104	.	PCB (SA 800, -5V, WITH DATA SEP)			
	25105	.	PCB (SA 800, -12/-15V, WITH DATA SEP)			
	25106	.	PCB (SA 801, -5V)			
	25107	.	PCB (SA 801, -12/-15V)			
-49	10140	.	BLOCK, PCB CONN			1
-50	10174	.	.SCREW, 4-40			2
-51	12036	.	SCREW, 8-32x.375			1
-52	10187	.	SCREW, 6-32x.250 -800R			2
-53	50669	.	CLIP, FACE PLATE MOUNT-800R			2
-54	10014	.	WASHER			1

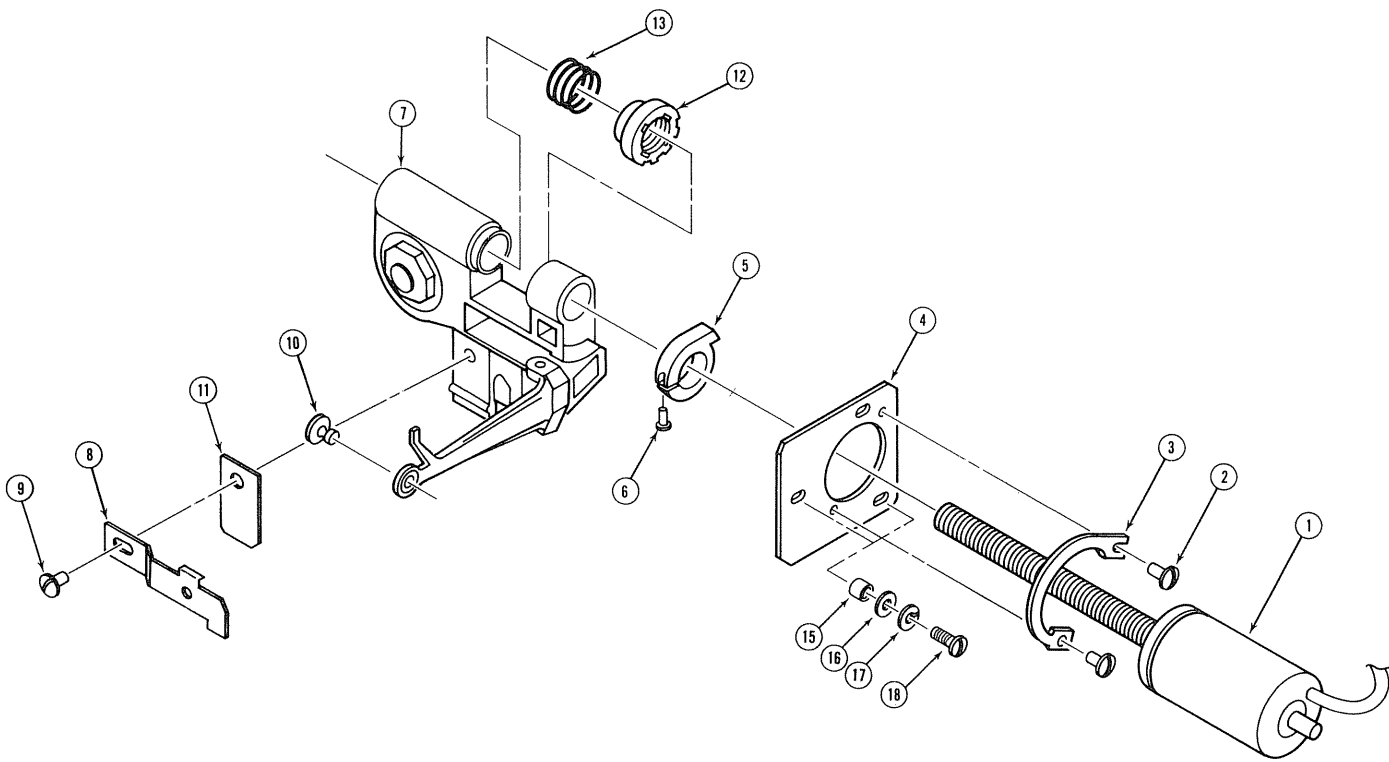

Figure 2

FIGURE & REF. NUMBER	PART NUMBER	DESCRIPTION				QTY PER ASM.
		1	2	3	4	
2-		STEPPER/CARRIAGE ASSEMBLY				
-1	50130	.	STEPPER MOTOR ASSEMBLY			1
-2	12016	.	SCREW, 8-32x.375			2
-3	50584	.	MOUNTING CLAMP			1
-4	50112-4	.	PLATE, STEPPER MOTOR			1
-5	50245	.	STOP, LIMIT - LEAD SCREW			1
-6	11903	.	SCREW, CAP 2-56x.250			1
-7	50562	.	CARRIAGE ASSEMBLY			1
-8	50529	.	.	FLAG, TRACK 0		1
-9	11910	.	.	SCREW. 4-40x.250		1
-10	50542	.	.	LOAD BUTTON		1
-11	50362	.	.	SPRING, PLATE		1
-12	50087	.	.	NUT		1
-13	50088	.	.	SPRING, PRE-LOAD		1
-14	10012	.	.	WASHER		1
-15	50707	.	SPACER			1
-16	10013	.	WASHER, #6 FLAT			3
-17	12510	.	WASHER, SPRING			3
-18	12027	.	SCREW, 6-32x.500			3

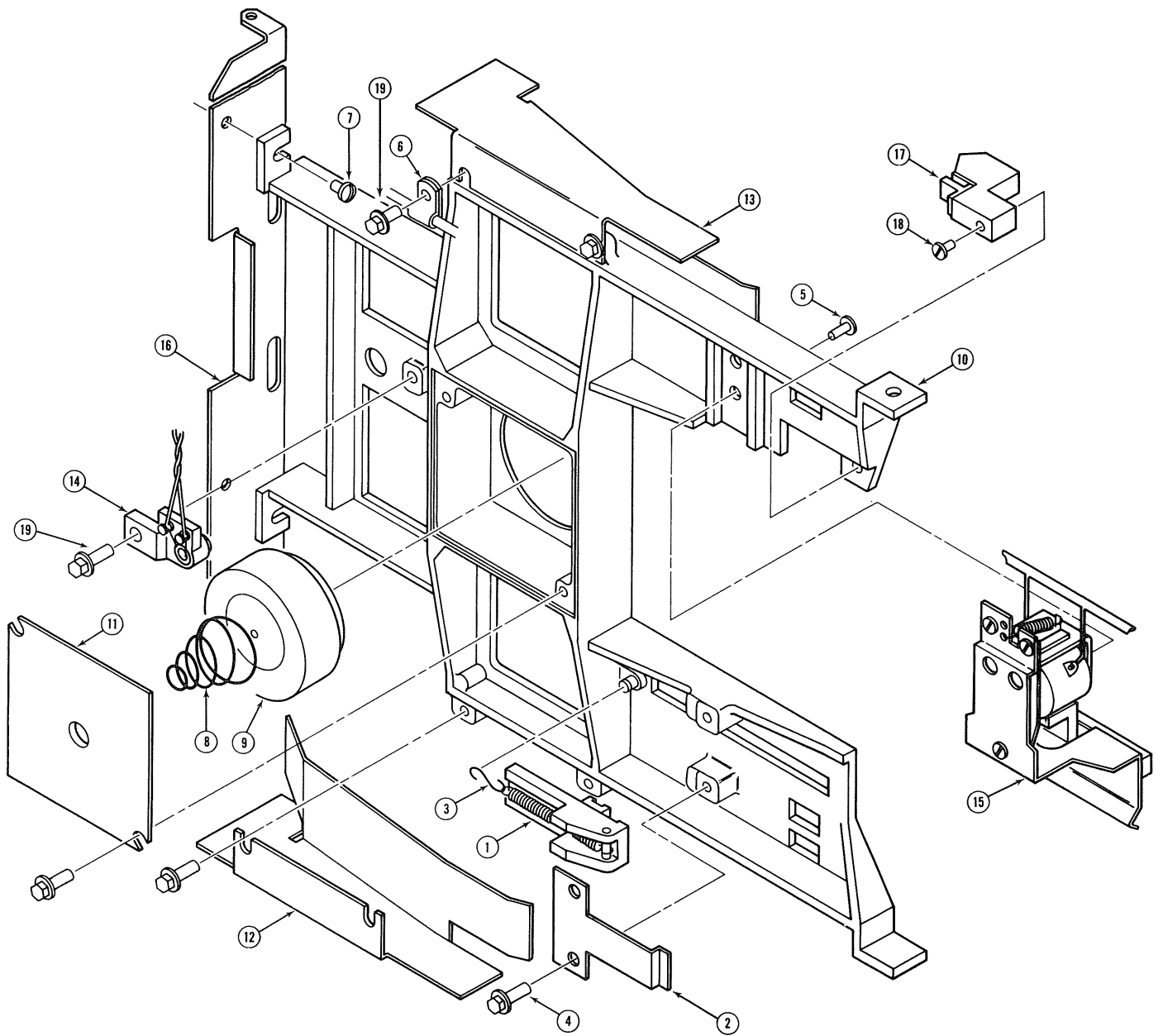
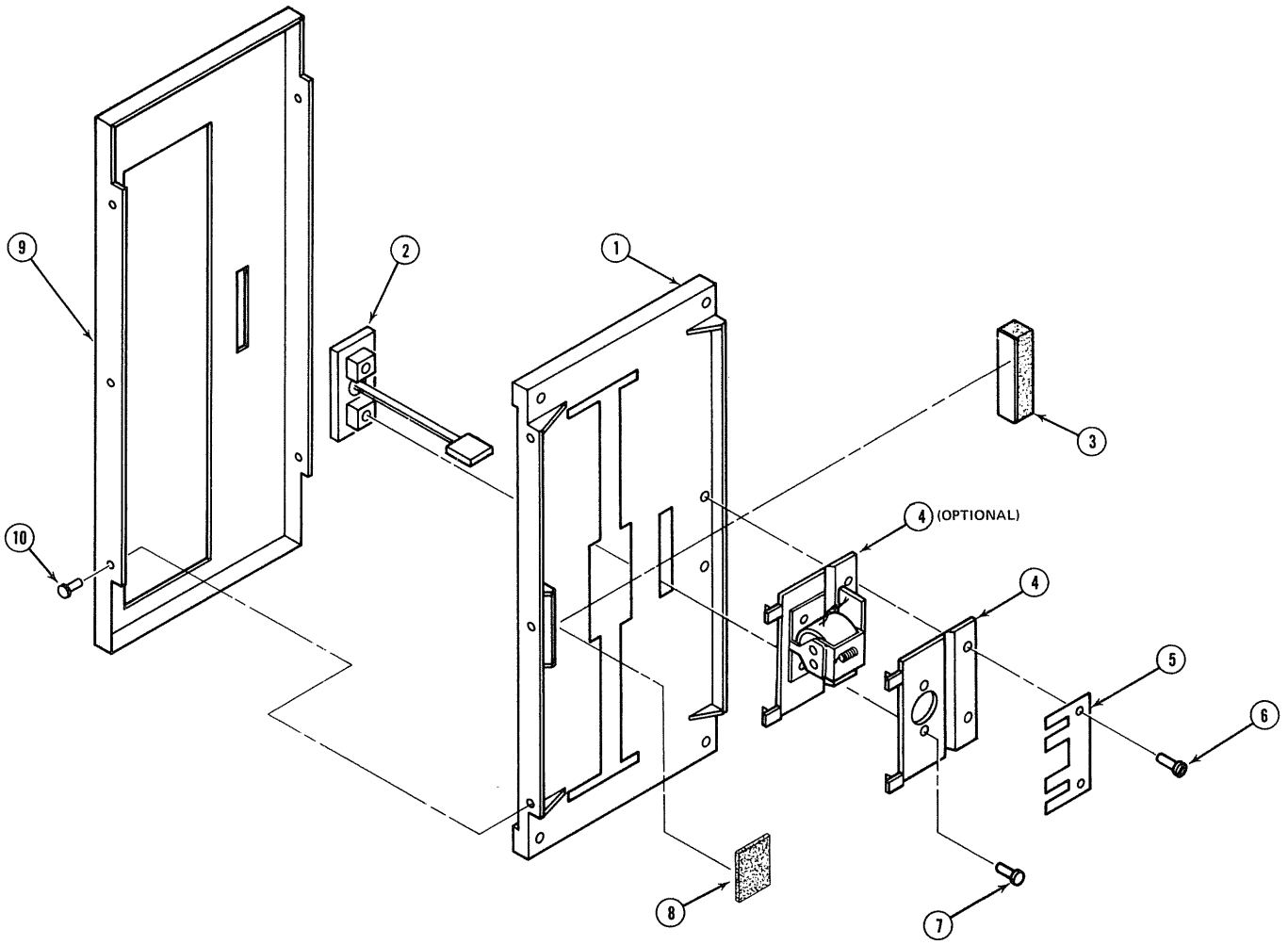

Figure 3

FIGURE & REF. NUMBER	PART NUMBER	DESCRIPTION				QTY PER ASM.
		1	2	3	4	
3-	50550	CARTRIDGE GUIDE ASSEMBLY				
1	50609	.	EJECTOR ASSEMBLY			1
2	50555	.	SPRING, CLAMP, EJECTOR			1
3	50556	.	HOOK, SPRING			1
4	12015	.	SCREW 8-32x.312			7
5	12013	.	SCREW 6-32x.312			1
6	10378	.	CLAMP, CABLE			1
7	10187	.	SCREW 6-32x.250			2
8	50031	.	SPRING, HUB CLAMP			1
9	50254	.	HUB CLAMP ASSEMBLY			1
10	50544	.	GUIDE			1
11	50546	.	PLATE, HUB CLAMP			1
12	50547	.	STRIPPER, BOTTOM			1
13	50548	.	STRIPPER, TOP			1
14	50557	.	L.E.D. ASSEMBLY			1
15	50558	.	HEAD LOAD ACTUATOR ASSEMBLY			1
16	50579	.	LATCH PLATE			1
17	50313	.	WRITE PROTECT DETECTOR ASSEMBLY			1
18	12026	.	SCREW 4-40x.625			1
19	12016	.	SCREW 8-32x.375			2



**Figure 4**

FIGURE & REF. NUMBER	PART NUMBER	DESCRIPTION				QTY PER ASM.
		1	2	3	4	
4-	50733	FRONT PLATE ASSEMBLY (WITH LITE)				
	50731	FRONT PLATE ASSEMBLY (WITHOUT LITE)				
	50735	FRONT PLATE ASM KIT (WITH DOOR LOCK)				
	50679	FRONT PLATE ASM-800R (WITHOUT LITE)				
	50680	FRONT PLATE ASM-800R (WITH LITE)				
	50724	FRONT PLATE ASM-800R (WITH DOOR LOCK)				
-1	50729	. FRONT PLATE				1
	50667	. FRONT PLATE-800R				1
-2	50727	. PUSH BUTTON (WITH LITE)				1
	50726	. PUSH BUTTON, DOOR LOCK OPTION				
-3	50728	. PUSH BUTTON (WITHOUT LITE)				1
	50183	. BUMPER				1
-4	50156	. LATCH				1
	50690	. LATCH ASM, DOOR LOCK OPTION				
-5	50691	. SPRING PLATE				1
-6	12013	. SCREW 6-32x.312				2
-7	12035	. SCREW 4-40x.250				2
-8	50580	. SNATCH				1
-9	50257	COVER, FRONT 5-1/4 x 11 WHITE				1
	50258	COVER, FRONT 5-1/4 x 11 TAN				1
	50260	COVER, FRONT 5-1/4 x 10 WHITE				1
	50261	COVER, FRONT 5-1/4 x 10 TAN				1
	50263	COVER, FRONT 4-5/8 x 10-1/2 WHITE				1
	50264	COVER, FRONT 4-5/8 x 10-1/2 TAN				1
	50675	COVER, FRONT-800R TAN				1
	10261	SCREW, FL. HD. 4-40x.250				5





PART NUMBER	FIG. REF.
10012	2-14
10013	2-16
10014	1-54
10025	1-2
10095	1-15
10140	1-49
10148	1-16
10150	1-14
10174	1-50
10187	3-7
	1-52
10191	1-24
10261	4-10
10264	1-46
10375	1-45
10378	1-23
	3-6
10800	1-6
10801	1-9
11305	1-38
11903	2-6
11904	1-22
11905	1-33
11910	2-9
12011	1-37
12012	1-27
12013	1-24
	3-5
	4-6
12015	1-11
	3-4
12016	
	2-2
	3-19
12023	1-25
12026	3-18
12027	2-18
12028	1-19
12032	1-42
12036	1-51
12500	1-12
12509	1-3
12510	2-17
15004	1-15
17200	1-36
25102	1-48
25103	1-48
25104	1-48
25105	1-48
25106	1-48
25107	1-48
50009	1-25
50016	1-4
50018	1-7
50019	1-5
50031	3-8

PART NUMBER	FIG. REF.
50087	2-12
50088	2-13
50098	1-18
50112-4	2-4
50121	1-28
50128	1-44
50130	2-1
50142	1-34
50156	4-4
50166	1-8
50167	1-31
50168	1-32
50183	4-3
50245	2-5
50254	3-9
50257	4-9
50258	4-9
50260	4-9
50261	4-9
50263	4-9
50264	4-9
50301	1-20
50313	3-17
50355	1-47
50356	1-47
50357	1-21
50358	1-21
50362	2-11
50440	1-25
50443	1-20
50522	1-26
50529	2-8
50542	2-10
50544	3-10
50546	3-11
50547	3-12
50548	3-13
50550	1-1
	3
50555	3-2
50556	3-3
50557	3-14
50558	3-15
50559	1-39
50561	1-10
50562	2-7
50579	3-16
50580	4-8
50582	1-30
50583	1-30
50584	2-3
50602	1-41
50609	3-1
50667	4-1
50669	1-53
50670	1-31

PART NUMBER	FIG. REF.
50675	4-9
50679	4
50680	4
50690	4-4
50691	4-5
50707	2-15
50724	4
50726	4-2
50727	4-2
50728	4-2
50729	4-1
50731	4
50733	4
50735	4





415 OAKMEAD PARKWAY, SUNNYVALE, CALIFORNIA 94086

PHONE: (408) 733-0100 • TWX: 910 339 9355 SHUGART SUVL